

THIS DRAWING IS UNPUBLISHED. RELEASED FOR PUBLICATION, 19
 © COPYRIGHT 19 BY AMP INCORPORATED. ALL INTERNATIONAL RIGHTS RESERVED.

LOC	DIST	P	F	ZONE	LTR	REVISIONS	DATE	APPD
AF	50				E	REDRAWN PER AF-6550	3/1/90	PF/JR

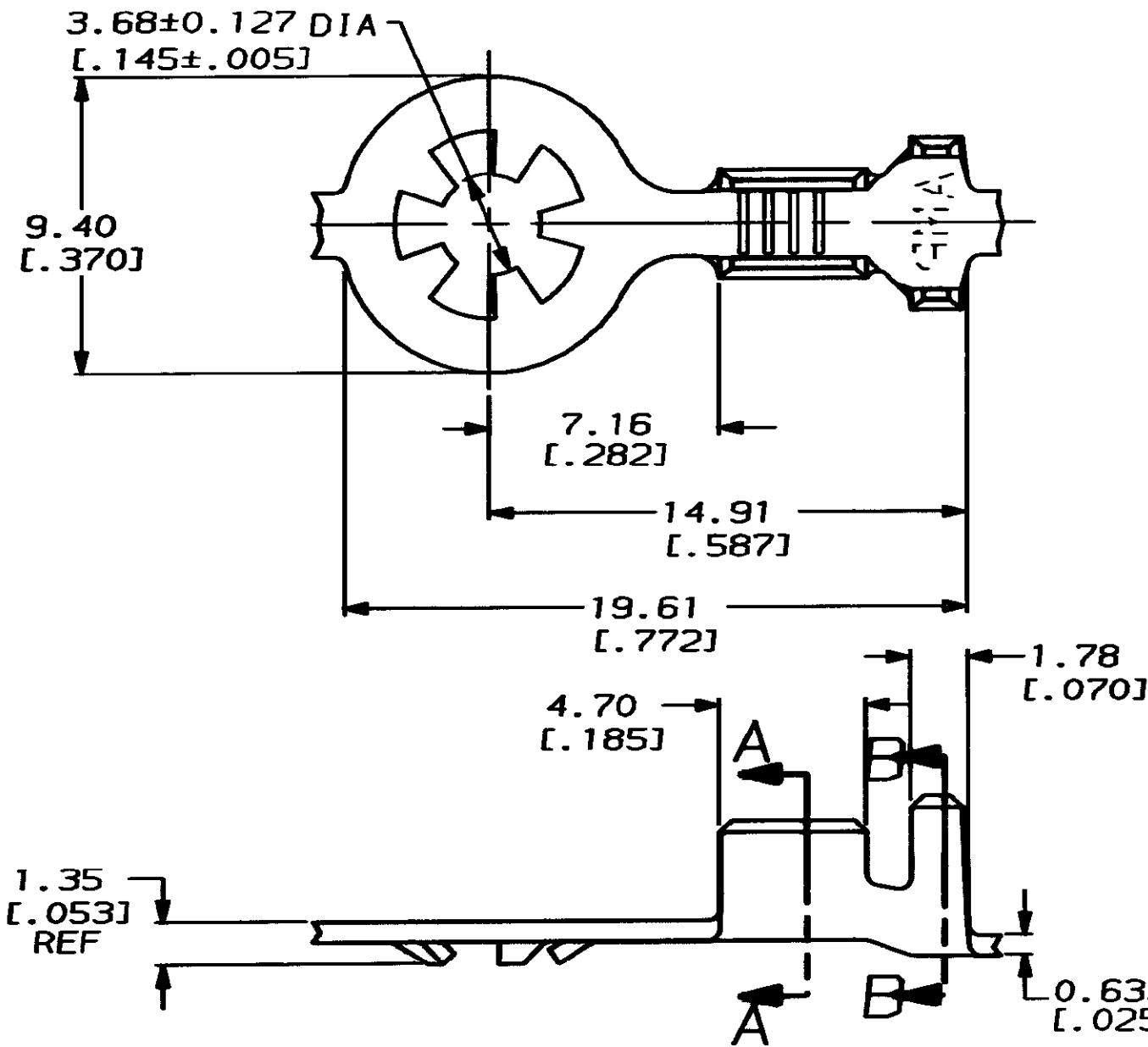

- 1 CONTINUOUS STRIP ON REELS
- △ 0.00203 [.000080] MIN TIN PL PER MIL-T-10727

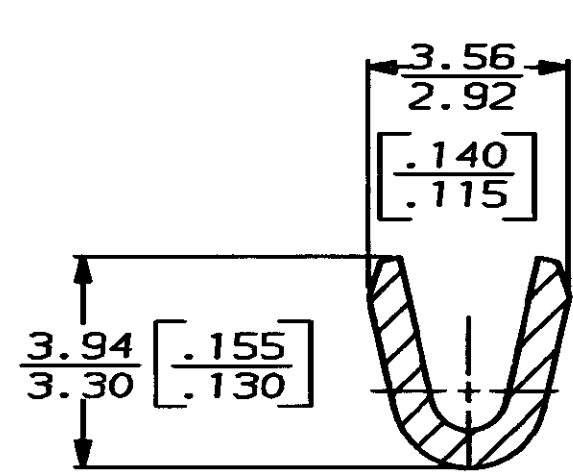

SECTION A-A
SCALE 8:1

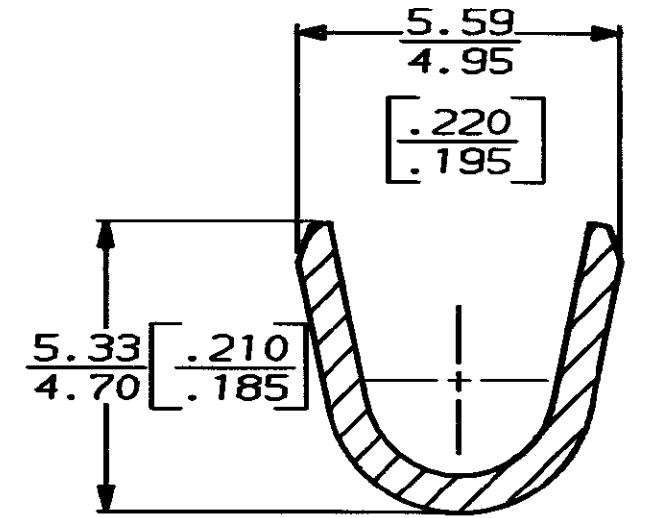

SECTION B-B
SCALE 8:1

METRIC

F	4.57 [.180]	6.35 [.250]	F	2.54 [.100]	2.11 [.083]	1.3mm ² [16]
					1.96 [.077]	0.8mm ² [18]
					1.85 [.073]	0.5mm ² [20]
					1.80 [.071]	0.3mm ² [22]
TYPE	WIDTH	STRIP LENGTH ±0.38 [±.015]	TYPE	WIDTH	HEIGHT ±0.051 [±.002]	WIRE
INSUL BARREL CRIMP			WIRE BARREL CRIMP			

△	2.54-3.56 [.100-.140]	0.3mm ² -1.3mm ² [22-16] AWG	61588-1
FINISH	INSULATION RANGE	WIRE SIZE	PART NO
DO NOT SCALE PRINT. UNLESS SPECIFIED DIMENSIONS IN mm (INCHES) TOLERANCES ON: 2 PLC DEC ± - 3 PLC DEC ± 0.38 [.015] ANGLES ± -	DR 3/1/90 P FORTNEY CHK 3/2/90 JR RUTH APPD 3/5/90 G YETTER APPD 3/12/90 R KLZD	AMP INCORPORATED Harrisburg, Pa. 17105	
MATERIAL	PRODUCT SPEC	RING	
#4 HARD BRASS	APPLICATION SPEC	SIZE	CAGE CODE
SEE TABLE		B	00779
	WEIGHT	DRAWING NO	61588
		SCALE	SHEET
		5:1	1 OF 1